

Specification For Approval

客户承认书

Customer (客户名称): _____

Battery model name (电池型号): GEB 1260100

Customer model number (客户料号): _____

Revision (版本): V1

Date (日期): 2016-12-08

Customer approval(客户承认)

Comment (备注):

Customer's signature/ Date(客户签名/日期) : _____

Prepared 制定	Checked 审核	Approved 批准

Content**目录**

1. Scope	1
适用范围	
2. Model: GEB1260100	2
编码规则	
3. Dimensions of battery pack	3
电芯尺寸	
4. Battery configuration	4
电池组	
5. Specification of cell	5
电芯规格	
6. Battery Cell Performance Criteria	6
电池性能检查及测试	
7. PCM parameter	8
PCM 参数	
8. Packing Storage and Transportation	10
包装、储存及运输	
9. Use Attentions	11
使用注意事项	

1.Scope

This document describes the Product Specification of the Lithium-Polymer (LIP) rechargeable battery cell supplied by General Electronics Battery Co., Ltd .

适用范围

本规格说明书描述了深圳市中美通用电池有限公司（以下简称中美通用）生产的可充电聚合物锂离子电池的产品性能指标

2. Model: GEB 1260100

型号: GEB 1260100

GEB—中美通用

PCB—保护板

3.Dimensions of battery pack

电池组尺寸 T:≤12.0mm * W:≤60mm * L :≤102mm

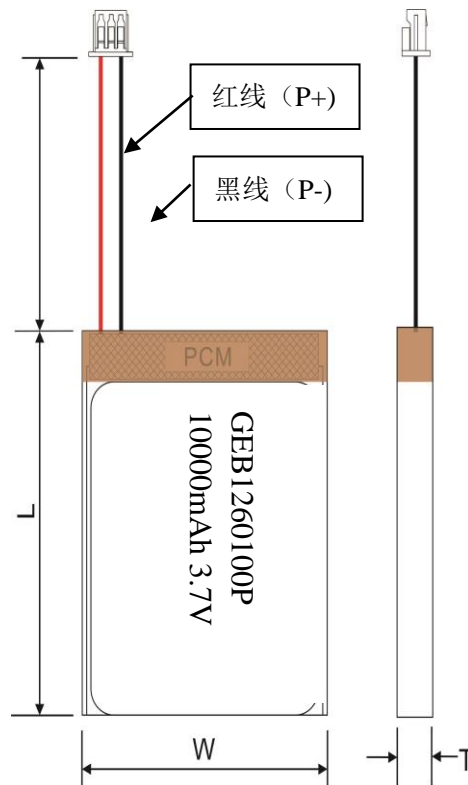

- Connecting Wires
接线方式
- Red: connect to “+”
红色接正极
- Black : connect to “ - ”
黑色接负极

4. Battery configuration 电池组

4.1 Battery portfolio primarily BOM

电池组合主要物料清单

No.	Item 项目	criteria 标准	Remarks 备注
1	Semi-manufactured cell 电芯型号	1260100	
2	PCB		SEIKO Plate 精工板
3	Wire/connector 线材/接头	UL1571-AWG24#, 左出线 The left outlet	

4.2 Specifications of battery pack

电池组规格

No.	Item 项目	Specifications 产品规格	Comments
1	Assemble mode 组装方式	Simple link 单节	
2	Nominal Capacity 标称容量	10000mAh	
3	Rated Impedance 初始内阻	10mΩ (Added after the board) at 25 °C (加板后) 常温 25°C	
4	Battery Weight 电池重量	Approx 145g 约 145g	
5	Overcharge protection voltage 过充保护电压	4.25±0.035V	
6	Max. charge current 最大充电电流	1 C	
7	Over discharge protection voltage 过放保护电压	2.75V	
8	Max discharge current 最大放电电流	1C	
9	Charge temperature 充电温度	0°C ~ +45°C	
10	Discharge temperature 放电温度	-10°C ~ +55°C	
11	Storage temperature 储存温度	less than 1 month 一个月以内	-10~+55°C
		less than 3 month 三个月以内	-10~+40°C
		less than 1 year 一年以内	0~+25°C
6	Storage humidity 储存湿度	≤ 75%	

5. Specifications of cell

电芯规格

No.	Items 项目	Specifications 产品规格	
1	Charge voltage 充电电压	4.2V	
2	Nominal voltage 标称电压	3.7V	
3	Nominal capacity 标称容量	10000mAh 0.2 C Discharge (0.2C 放电)	
4	Charge current 充电电流	Standard Charging:: 0.2 C 标准充电: 0.2 C Rapid charge: 1.0 C 快速充电 1.0 C	
5	Standard Charge 标准充电方式	Charging the cell initially with constant current at 0.2 C and then with constant voltage at 4.2V till charge current declines to 0.02 C 先用 0.2 C 恒流充电至 4.2V, 再恒压 4.2V 充电直至充电电流 ≤0.02 C	
6	Charging time 充电时间	Standard Charging: 6.0 hours (Ref.) 标准充电: 6.0 小时 (参考值) Rapid charge: 1.5-2.5 hours (Ref.) 快速充电: 1.5-2.5 小时 (参考值)	
7	Max.charge current 最大充电电流	1.0 C	
8	Max.discharge current 最大放电电流	1.0C	
9	Discharge cut-off voltage 放电截止电压	2.75V	
	Charge temperature 充电温度	0°C ~ +45°C	
10	Discharge temperature 放电温度	-10 ~ +55°C	
11	Temperature range for storage 储存温度范围	less than 1 month 一个月以内	-10~+55°C
		less than 3 month 三个月以内	-10~+40°C
		less than 1 year 一年以内	0~+25°C
6	Cell Weight 电芯重量	Approx: 142g 约: 142g	
13	Cell Dimension 电芯尺寸	Length 长度: 100 mm Max Width 宽度: 60 mm Max Thickness 厚度: 12.0 mm Max	

6. Battery Cell Performance Criteria

电芯性能检查及测试

6.1 Electrical characteristics 充放电性能

No.	Items 项目	Test Method and Condition 测试方法和条件	Criteria 标准
6.1.1	Standard Charge 标准充电方式	Charging the cell initially with constant current at 0.2 C and then with constant voltage at 4.2V till charge current declines to 0.02 C 先用 0.2 C 恒流充电至 4.2V, 再恒压 4.2V 充电直至充电电流 $\leq 0.02 C$	
6.1.2	First Discharge Capacity 首次放电容量	The capacity means the first dis charge capacity of the cell, which is measured with discharge current of 0.5 C with 2.75V cut-off after standard charge. 该容量是指标准充电后, 0.5C 放电至 2.75V 截止所放出的容量。	$\geq 10000mAh$
6.1.3	Cycle Life 循环寿命	Test condition: Charge: 0.2 C to 4.2V Discharge: 0.2 C to 2.75V 80% or more of 1 st cycle capacity at 0.2C discharge of Operation 测试条件: 充电: 0.2 C 充电到 4.2V 放电: 0.2 C 放电到 2.75V 当放电容量降至初始容量的 80% 时, 所完成的循环次数定义为该电池的循环寿命	≥ 800 周 (laps)
6.1.4	Self-discharge 自放电	After the standard charging, storied the cells under the condition $25.0 \pm 5.0^{\circ}C$ (Temperature) $\leq 75.0\%RH$ (Humidity) for 28 days, then measured the capacity with 0.2 C till 2.75V with previous standard discharge capacity of the ratio 标准充电后, 在 $25^{\circ}C \pm 5^{\circ}C$ (温度) $\leq 75\%RH$ (湿度) 条件下贮存 28 天, 再以 0.2 C 放电至 2.75V 所放出的容量与前次标准放电容量的比值。	Residual capacity $> 90\%$ 余容量 $> 90\%$
6.1.5	Initial impedance of cell 电池初始内阻	Internal resistance measured at AC 1KHz after 50% charge , at $25^{\circ}C$. 在 $25^{\circ}C$ 环境中, 半充状态下, 测量其 AC 1KHz 下的交流阻抗	$\leq 10m\Omega$
6.1.6	Temperature Characteristics 温度特性	1. According to item 6.1.1, at $25 \pm 5^{\circ}C$. 2. Capacity comparison at each temperature, measured with constant discharge current 0.2 C with 2.75V cut-off. Percentage as an index of the capacity compared with 100% at $25^{\circ}C$ 1. 在 $25 \pm 5^{\circ}C$ 条件下, 用 6.1.1 方法将电池充电。 2. 在不同温度条件下, 用 0.2 C 的电流恒流放电至截止电压 2.75V。以 $25^{\circ}C$ 时放电容量为基准计算百分比。	$-10^{\circ}C: \geq 50\%$ $25^{\circ}C: 100\%$ $60^{\circ}C: \geq 85\%$
6.1.7	Constant humidity and temperature 恒定湿热	After standard charging, laying the battery 48h at $40 \pm 2^{\circ}C$, RH $93 \pm 2\%$. Recording 1C discharging time 电池标准充电后在 $40 \pm 2^{\circ}C$, 相对湿度 $93 \pm 2\%$ 环境中放置 48h, 用 1C 放电至截止电压 2.750V, 记录电池放电时间	No distortion No electrolytes leakage 不变形、不漏液, 放电时间 $\geq 36min$

6.2 Mechanical characteristics

机械特性

No.	Items 项目	Test Method and Condition 测试方法和条件	Criteria 标准
1	Vibration Test 振动测试	<p>After standard charging, fixed the cell to vibration table and subjected to vibration cycling that the frequency is to be varied at the rate of 1Hz per minute between 10Hz and 55Hz, the excursion of the vibration is 1.6mm. The cell shall be vibrated for 30 minutes per axis of XYZ axes.</p> <p>将标准充电后的电池固定在振动台上，沿 X、Y、Z 三个方向各振动 30 分钟，振幅 1.6 mm，振动频率为 10Hz~55Hz，每分钟变化为 1Hz。</p>	<p>No leakage 无泄漏 No fire 不起火</p>
2	Drop Test 跌落测试	<p>The cell is to be dropped from a height of meter twice onto concrete ground.</p> <p>将标准充电后的电池从 1 米高度跌落至混凝土地面 2 次</p>	<p>No fire, no leakage. 无起火、无泄漏</p>

6.3 Visual inspection

There shall be no such defect as scratch, flaw, crack, and leakage, which may adversely affect commercial value of the cell.

外观检查

不允许有任何影响电池性能的外观缺陷，诸如裂纹、裂缝、泄漏等。

6.4 Standard environmental test condition

Unless otherwise specified, all tests stated in this Product Specification are conducted at below condition:

Temperature: 25.0±5.0°C

Humidity: ≤75.0%RH

标准测试环境

除非特别说明，本标准书中所有测试均在以下环境条件下进行：

温度：25.0±5.0°C

湿度：≤75.0%RH

7. PCM parameter PCM 参数

7.1 PCM 参数

Item 项目	Symbol 符号	Content 详细内容	Criteria 标准
Over charge Protection 过充保护	V _{DET1}	Over charge detection voltage 过充电检测电压	4.25V ± 0.03V
Over discharge 过放保护	V _{DET2}	Over discharge detection voltage 过放电检测电压	2.75V ± 0.08V
Over Current 过流保护	I _{DP}	Over current detection current 过电流保护电流	20A
Interior resistance 内阻	R _{DS}	Main loop electrify resistance (Battery Vol=3.9V) 主回路通态电阻 (电池电压=3.9V)	B- to P- B-至 P- R _{DS} ≤ 60mΩ
			PTC R _{DS} ≤ 1.2Ω
Current consumption 消耗电流	I _{DD}	Current consume in normal operation 工作时电路内部消耗	MIN: 0.3 μA MAX: 8.0 μA

7.2 Application Schematic

应用原理图

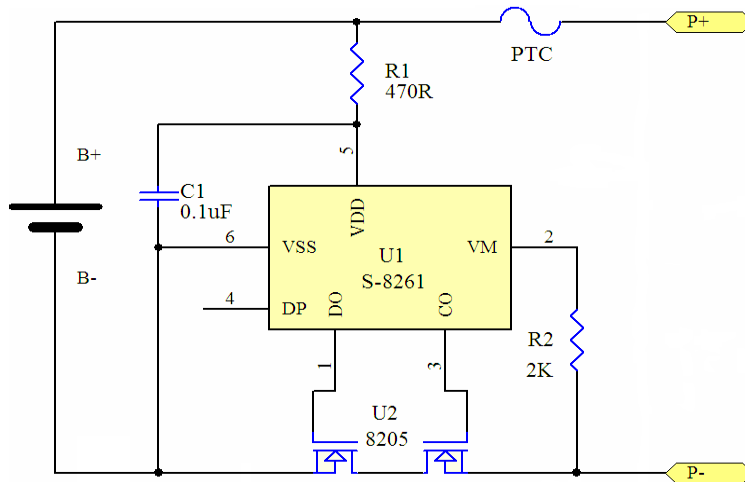

8. Packaging、 Storage and Transportation 包装、储存及运输

8.1 Packaging model

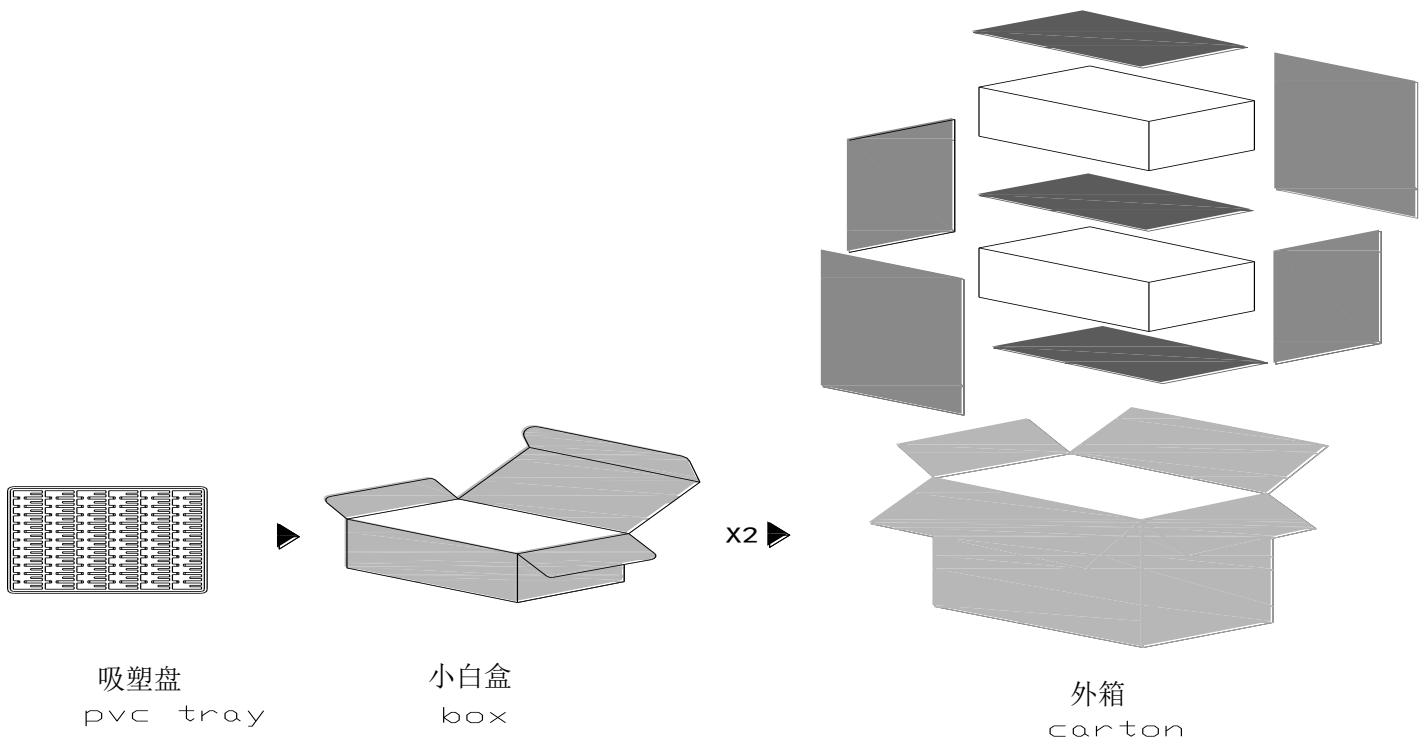

8.2 Storage 储存:

8.2.1 The Li-ion battery pack should be stored in a cool, dry and well-ventilated area, and should be far from the fire and the high temperature.

锂离子电池需保存在阴凉，干燥，通风的环境中，避免接触火源与热源。

8.2.2 The battery should store in the product specification book stipulation temperature range, the best storage temp. is $25\pm 5^{\circ}\text{C}$. The best humidity is $60\pm 15\%$.

电池需按规格书规定温度范围进行储存，最佳储存温度为 $25\pm 5^{\circ}\text{C}$ ，最佳湿度为 $60\pm 15\%$ 。

8.2.3 The battery should be stored within room temperature, and charged to 40%~60% electric quantity (3.85V). In order to avoid over-discharge, we suggest charge and discharge the batteries every three months.,Then charge to 40%~60% electric quantity (3.85V).

电池应当在室温下存放，应充到 40% 至 60% 的电量 (3.85V)。为防止电池过放，建议每 3 个月按标准充放电方式进行一次充电,然后按标准充电方式进行充电至 40%~60% 的电量 (3.85V)。

8.3 Transportation 运输:

8.3.1 Do not mix the battery products with other car gos.

请勿与其他货物混合。

8.3.2 Do not immerse the battery products in water or allow it to get wet.

请勿将电池浸入水中或使其受潮。

8.3.3 Do not over 7 layers staking and upside-down.

请勿叠放超过 7 层或倒置。

8.3.4 The highest temperature in transportation is lower than 65°C .

最高运输温度不超过 65°C 。

9. Use Attentions 使用注意事项:

To ensure proper use of the battery please read the manual carefully before using it.

为确保电池正确使用，请在使用之前阅读使用说明书。

9.1 Warnings 警告:

9.1.1 Do not expose to, dispose of the battery in fire.

不可将电池置于火中。

9.1.2 Do not put the battery in a charger or equipment with wrong terminals connected.

不可将电池充电器正负极反接。

9.1.3 Avoid shorting the battery.

不可将电池短路(P+, P-)。

9.1.4 Avoid excessive physical shock or vibration.

避免电池过度冲击和震荡。

9.1.5 Do not disassemble or deform the battery.

不可拆解或扭曲电池。

9.1.6 Do not immerse in water.

不可浸入水中。

9.1.7 Do not use the battery mixed with other different type or model batteries.

不可将该电池与其他种类和型号的电池混用。

9.1.8 Keep out of the reach of children.

请置于儿童接触不到的地方。

9.2 Charge 充电:

9.2.1 Battery must be charged in appropriate charger only.

请使用合适的充电器对电池充电。

9.2.2 Never use a modified or damaged charger.

请勿用返修或损坏过的充电器充电。

9.2.3 Do not leave battery in charger over 24 hours.

请勿对电池充电 24H 以上。

9.2.4 Charging current: Can not surpass the biggest charging current which in this specification book stipulated.

不可使用超出本规格书最大充电电流对电池进行充电。

9.2.5 Charging voltage: Does not have to surpass the highest amount which in this specification book stipulated to decide the voltage.

充电电压: 请不要超出本规格书所规定最高充电电压。

9.2.6 Charge temperature: The battery must carry on the charge in the ambient temperature scope which this specification book stipulated.

充电温度: 电池需在指定温度范围内进行充放电。

9.2.7 Uses constant current and constant voltage way charge. PLS connect the positive and negative terminals in right way, or the battery may be damaged.

请使用恒流恒压方式进行充电。请勿反接正负极, 以免损坏电池。

9.3 Discharge 放电:

9.3.1 The discharging current should not surpass the biggest discharging current this specification book stipulation, The large discharge current can cause heat and lower capacity.

放电电流不可超过规格书最大额定放电电流。大电流会导致电池发热和容量降低。

9.3.2 Discharge temperature: The battery discharge must carry on in the ambient temperature scope which this specification book stipulated.

放电温度: 电池必须在规格书规定温度范围内放电。

9.3.3 Over-discharge: After short time over discharge, then charge immediately won't damage the battery. But the battery will be damaged for being long time over discharged. During long-term storage, the battery may be within over-discharging condition for self discharge. To prevent the occurrence of over discharging, the battery should maintain the certain capacity when storage.

过放电: 电池瞬间过放后立即充电不会损坏电池。但是如果长时间过放, 电池将会被损坏。在长期储存中, 可能由于电池自放电而导致电池处于过放状态。因此为避免电池过放, 必须带电储存。

9.4 Handling of Cells 电池操作注意事项

1 Soft Al foil (铝箔软包装)

- Don't strike battery with any sharp edge parts 勿用尖锐处撞击电池。
- Trim your nail or wear glove before taking battery 剪掉指甲, 或者戴手套。
- Clean worktable to make sure no any sharp particle 清理工作台, 避免尖锐零部件。

2 Sealed edge may be damaged by heat above 100°C, bend or fold sealed edge.

封边被加热到 100°C 以上以及弯折封边都容易使封边受损。

3 Handling of Tabs (极耳操作注意事项)

The battery tabs are not so stubborn especially for aluminous tab.

Do not bend tabs unnecessarily.

极耳的机械强度并非异常坚固, 特别是铝极耳。没有必要时禁止弯折极耳。

4 Tab Connection (极耳连接)

Ultrasonic welding or spot welding is recommended for LIP tab connection method.

Battery pack should be designed that shear force are not applied to the LIP tabs.

If apply manual solder method to connect tab with PCM, below notice is very important to ensure battery performance:

- The solder iron should be temperature controlled and ESD safe;
- Soldering temperature should not exceed 370°C;
- Soldering time should not be longer than 3s;
- Soldering times should not exceed 5 times, Keep battery tab cold down before next time soldering;
- Directly heat cell body is strictly prohibited, Battery may be damaged by heat above approx. 100°C

建议使用超声波或点焊焊接方法; 外壳设计应使极片不受外力。

如果使用人工焊接保护板, 下面的注意事项对于确保电池性能非常重要:

- 焊接烙铁的温度必须可控且可防静电;
- 焊接时烙铁的温度不能超过 370°C;
- 焊锡时间不能超过 3 秒钟;
- 焊锡次数不能超过 5 次, 待极片冷却后才能进行下一次焊锡;
- 严禁直接加热电芯, 高于 100°C 度会损害电芯。

9.5 Disposal 处理措施:

Regulations vary for different countries. Dispose of in accordance with local regulations.

不同国家有不同规定。请按当地规定进行处理。

9.6 Note:

Any other items which are not covered in this specification shall be agreed by both parties.

规格书所未包含的其它条款由双方协议解决。